

---

---

### INSTALLATION MANUAL

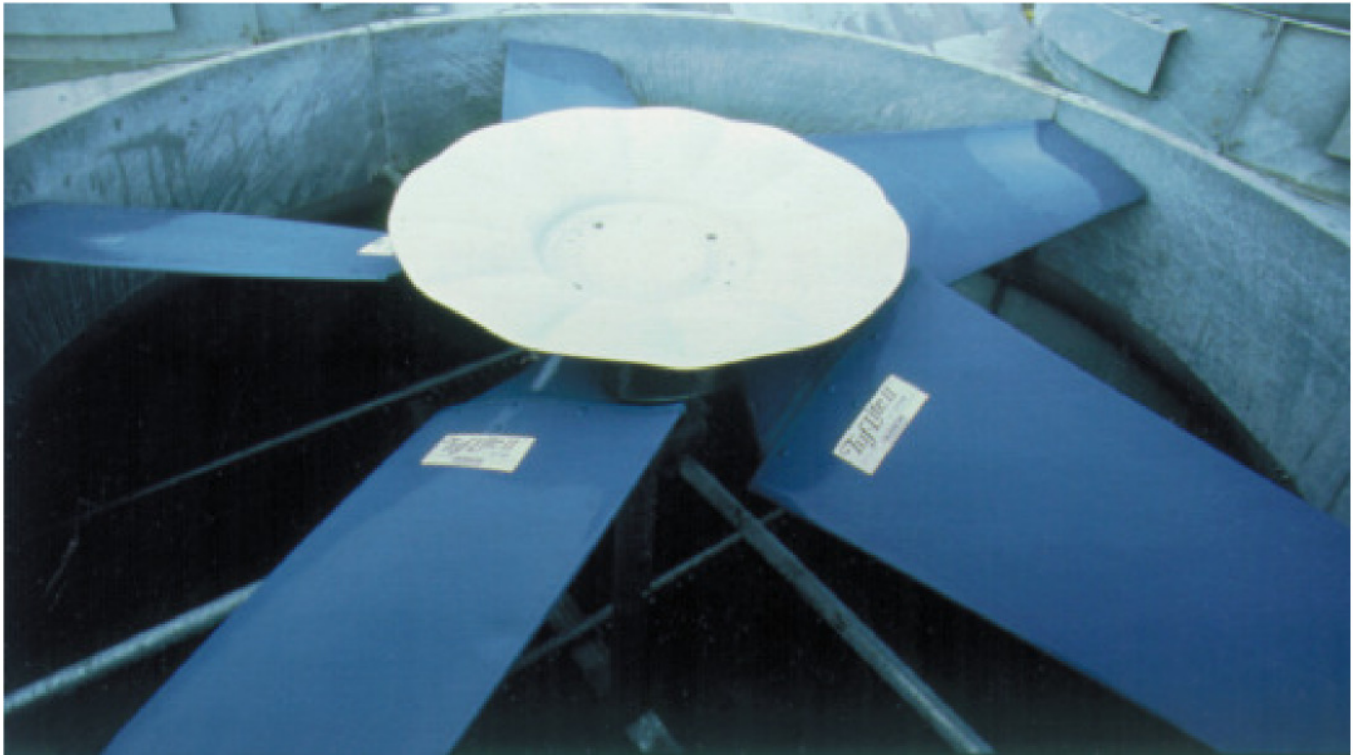

### Adjustable Pitch Fan Assembly 5' through 14' Diameter

#### *Hudson Tuf-Lite II® Fan Blades*

Hudson Tuf-Lite II® (white, prev. blue\*\*) fan blades are made from fiberglass reinforced vinyl-ester resin having a very high strength-to-weight ratio and superior ultra-violet and corrosion resistance. An elastomeric blade/holder joint cover (not shown) prevents moisture from entering (shown above).

The individually balanced blades can be replaced independently - matched sets are not required.

This manual now includes the latest Hudson standard fans. The fan line now starts at 5 ft diameter and blade counts now include 10-15 inclusive. These new fans deploy different hub and seal disc sizes as shown in the Parts List on Page 6 of 8. This same list shows the original fans highlighted.

## RECOMMENDED TOOLS

- Long T-Handle Allen Wrench Set (3/16" to 3/8")
  - Medium Size Flat Head Screw Driver
  - Brass Ball Peen Hammer
  - Flat Bastard File
  - 240 Grit Sand Paper
  - Anti-Seize Lubricant
  - WD-40
  - 12" Crescent Wrench
- Shop Towels
  - Exact-A-Pitch® Digital Protractor (P/N 62375)
  - 25 ft. Measuring Tape
  - Pencil or Marker
  - Open/Box End Wrench Set (1/2" - 1- 1/2")
  - Socket Set for 1/2" Drive (1/2" - 1 -1/2")
  - Torque Wrench(s) Rated for 0-200 ft-lb

## INSTALLATION PROCEDURES

### *ASSEMBLY WITH BUSHING*

Clean all mating surfaces between hub, bushing and shaft. All grease and lubricant should be removed, leaving the mating surfaces dry.

If there is no shoulder on shaft to prevent bushing from sliding down shaft, slide spacer/sleeve (not provided) on shaft before bushing. Slide bushing and key onto shaft until flush with end of shaft. The shaft size determines the bushing type (Q2 or R2). Lock bushing on shaft by tightening the set screw in flange with an Allen Wrench. (Note: Q2 bushings have no set screws.) Line up key and set hub on bushing. Engage the three (3) cap screws in flange of bushing into hub spool, using a torque wrench with a socket, and tighten evenly. Use the following table to determine the proper tools and torque values. Cap screw(s) for retainer plate are not required for bushing application.

Bushing Size	Allen Wrench Size	Cap Screw Size	Socket Size	Torque (ft-lb) Dry
Q2	-	3/8"	9/16"	29
R2	3/16"	3/8"	9/16"	29

### *ASSEMBLY WITH STRAIGHT SHAFT (NO BUSHING)*

Clean all mating surfaces between the hub and the shaft. If there is no shoulder on shaft to prevent hub from sliding down shaft, slide spacer/sleeve (not provided) on shaft before hub. Install key in shaft. Line up key and keyway and set hub on shaft. Tighten set screw(s) in hub.

### *ASSEMBLY WITH TAPERED SHAFT (NO BUSHING REQUIRED)*

Clean all mating surfaces between the hub and shaft. Align keyways and install hub. Install retainer plate and cap screw(s) with lock washer(s). Shaft size determines what size cap screw is necessary. Using a torque wrench with a socket, evenly tighten cap screw to recommended standard per table below.

Cap Screw Size	Socket Size	Torque Value (ft-lb)	
		Lubricated	Dry
5/8" NC	15/16"	80	90
3/4" NC	1-1/8"	100	110
1" NC	1-1/2"	150	160

NOTE: Retaining arrangement varies with gear shaft design.

## BLADE INSTALLATION

To prevent installation problems, work on one blade at a time. Remove blade clamp bolts, nuts, lock washers, and blade clamp halves from hub. Discard the plastic shipping spacers between the upper and lower blade clamp halves. Assemble blade clamp halves over groove in blade neck, and install into hub (See Figure 1). The thick leading edge will be to your left and thin trailing edge will be to your right as you stand at end of blade.



Figure 1

Install clamp bolts through hub plates and blade clamp, putting bolt heads on top, lock washers and nuts on bottom (See Figure 2). Tighten lightly.

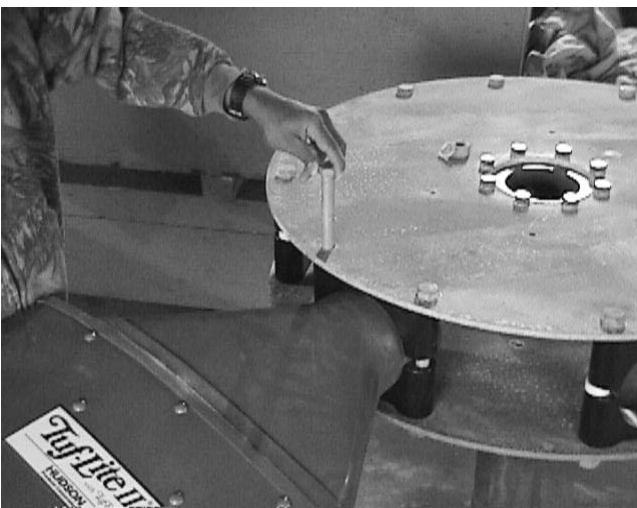

Figure 2

## SET PITCH AND TRACK

Use Hudson's EXACT-A-PITCH<sup>®</sup> digital protractor (See Figure 3) or a bubble protractor to set blade pitch. Mount protractor on a flat bar as a base and place it approximately 1" from tip of blade. Note pitch on protractor. Rotate fan 360°, noting high and low pitch readings. Locate place where pitch reading is at midpoint between high and low readings, and set pitch at that point.



Figure 3

Rotate blade in clamp until digital protractor shows specified pitch angle to within  $\pm 0.2^\circ$ . Fan pitch angle is shown on fan specification sheet for design duty. After desired pitch angle is set, raise and lower end of fan blade and find midpoint of blade travel. Hold blade at the midpoint. Pull blade outward so that the blade neck flange rests against the back of the blade clamps. Push blade to the right to remove all slack.

Use torque wrench to tighten clamp bolts to 65 ft-lb (lubricated) or 80 ft-lb (dry). Re-check pitch setting. Blade must be set within  $\pm 0.2^\circ$  of desired pitch angle. Tighten clamp bolts evenly. **DO NOT OVER-TORQUE CLAMP BOLTS.**

When bolts are tightened, hold a pencil against top end of blade and mark the level onto a fixed object, such as a pole or the fan ring.

Install remaining blades at same place as first blade, following the instructions above. After tightening bolts, mark top end of each blade in the same place first blade was marked. If marks differ by more than 1/2", adjust blade.

## CHECK TRACK

After fan is installed in fan stack cylinder ring, outline the top side of each blade onto fan stack cylinder ring with a marker (See Figure 4). The difference between levels of highest and lowest outlines should not be more than 1/2". Correct blade track by loosening clamp bolts and adjusting blade to match track of other blades. Re-tighten bolts and re-check track and pitch angle setting. Re-tighten blade clamp bolts to recommended standard of 65 ft-lb (lubricated) or 80 ft-lb (dry) torque.



Figure 4

## SEAL DISC INSTALLATION

### For 4 to 9 Blades

Fasten seal disc to top of hub with four (4) 3/8" cap screws, as shown in figures 5 and 6. Tighten to recommended standard of 15 ft-lb (lubricated) or 20 ft-lb (dry).



Figure 5

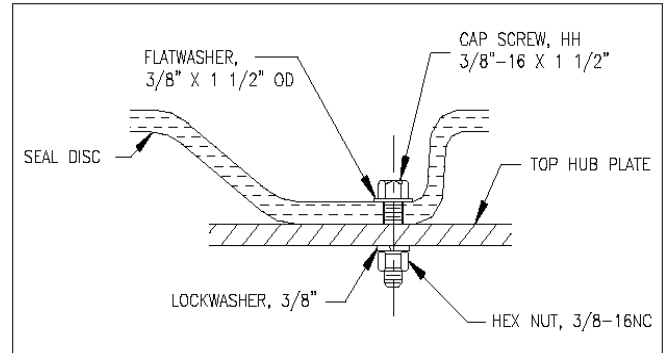

Figure 6

### For 10 to 15 Blades

Install 3/8" NC bolts at six (6) places on top hub plate (See Figure 6a & 6b). Threaded portion of bolts must be pointing up to mount seal disc. Install lock washer, nut, and flat washer on each bolt. Tighten 3/8" NC nuts to 15 ft-lb (lubricated) and 20 ft-lb (dry).

Locate the six (6) mounting holes in seal disc and install over the six (6) bolts pointing up on upper hub plate. If difficulty is encountered, loosen bolts on seal flanges until seal disc can be mounted, then re-tighten to 15 ft-lb (lubricated) or 20 ft-lb (dry).

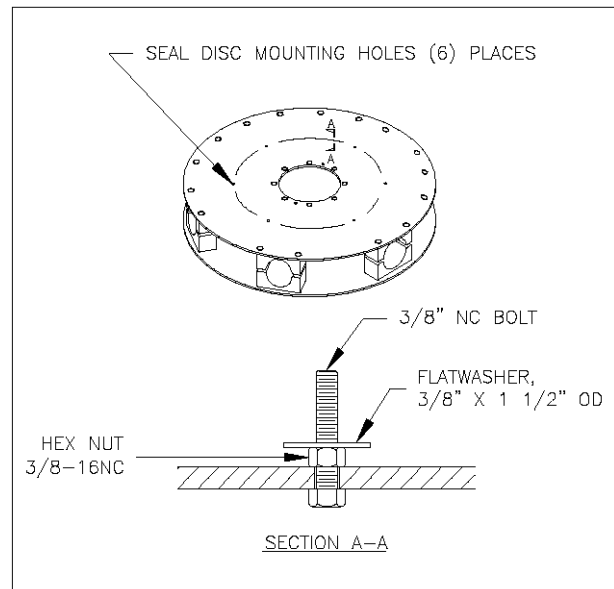

Figure 6a



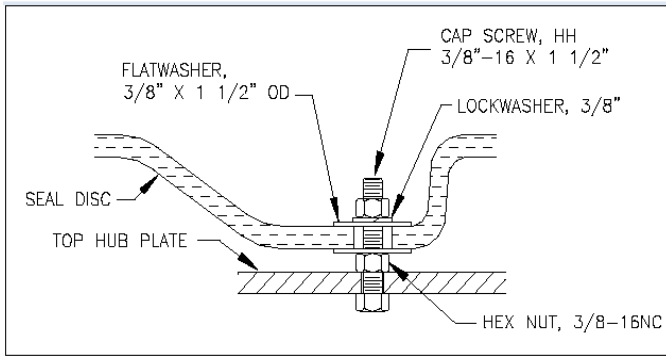

Figure 6b

NOTE: The purpose of the seal disc is to prevent hot air from re-circulating back down through the hub, increasing efficiency.

### CHECKING TIP CLEARANCE

Rotate fan in position inside fan ring or fan stack to check tip clearance (See Figure 7). The recommended tip clearance is shown in the table below. Check for spots where fan blade clearance is not within the recommended tolerance.

Fan Diameter	Minimum	Maximum
5' through 9'	1/4"	1/2"
>9' through 11'	1/4"	5/8"
>11' through 14'	1/4"	3/4"



Figure 7

If necessary, adjust fan ring or fan stack by shimming to obtain proper clearance. For heat exchangers, spacers may be added at the fan ring joints to increase clearance (See Figure 8). Use a chisel to maintain the correct gap until the bolts on the ring are re-tightened.



Figure 8

If a small adjustment is needed, tighten or loosen nut on fan strut in section requiring adjustment (See Figure 9).



Figure 9

### OPERATING INSTRUCTIONS

Start fan and check rotation. Viewed from top (discharge), fan blades should rotate clockwise.

Check motor power consumption to be sure fan is pulling desired load. **CAUTION:** If positive pitch is set in summer to use all available motor amps (nameplate rating), motor could be overloaded in winter. Design pitch angles usually do not use all of the available motor horsepower. This ensures that the motors will not be overloaded at low winter temperatures.



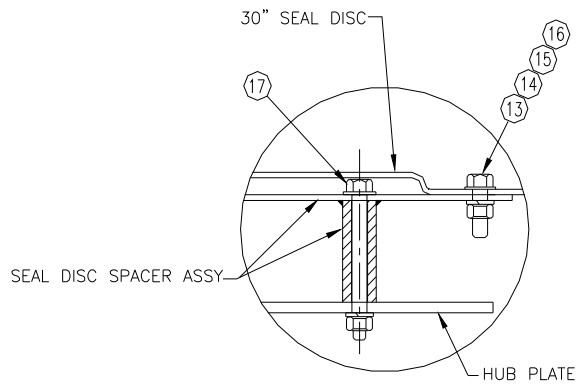
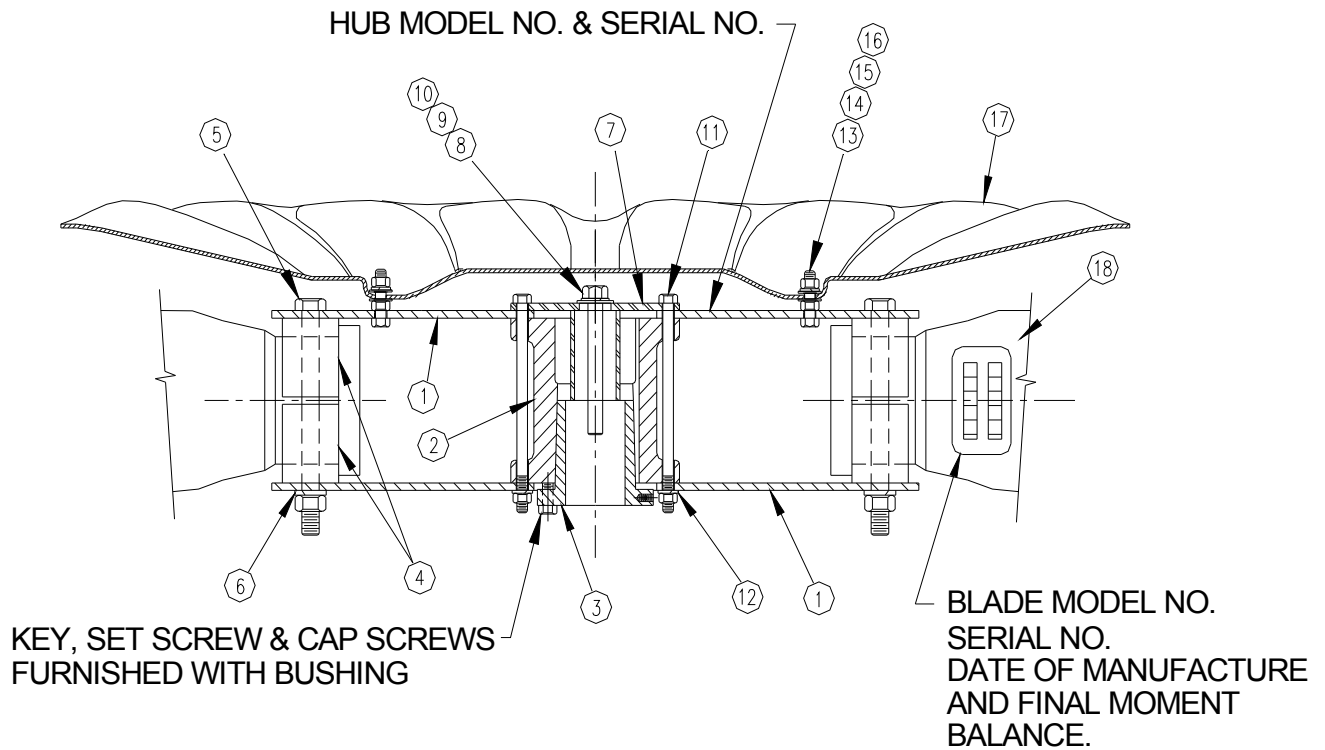

**SEAL DISC SPACER MOUNTING FOR 5H HUB ASSY**

**HUDSON PRODUCTS CORPORATION**  
 Adjustable Pitch Fan Assembly 5' Thru 14' Diameter  
 Series 3000H HUB

# **HUDSON**

## **Products Corporation**

1307 Soldiers Field Drive  
Sugar Land, Texas 77479-4072  
Post Office Box 20029  
Sugar Land, Texas 77496-0029  
Phone: (281) 275-8100  
Fax: (281) 275-8388  
1-800-634-9160 (24 Hours)

[EMAIL: HUDSON.products@HUDSONproducts.com](mailto:HUDSON.products@HUDSONproducts.com)  
<http://www.HUDSONproducts.com>

*Hudson, Auto-Variable, Combin-Aire, Exact-A-Pitch, Fin-Fan, Heatflo, Hy-Fin, Split-Flo, Solo Aire, Stac-Flo, Steamflo, Thermflo, Tuf-Edge, Tuf-Lite, and Tuf-Lite II are registered trademarks of Hudson Products Corporation.*