INSTALLATION MANUAL



Adjustable Pitch Fan Assembly 32.8' or 10 Meter Diameter

Hudson Tuf-Lite III® fan blades

Hudson Tuf-Lite III® fan blades are of single piece fiberglass reinforced plastic (FRP) construction optimized for performance, reliability, noise, and cost effectiveness. Tuf-Lite III® fan blades are constructed of light weight, corrosion-resistant, fiberglass reinforced vinyl-ester resin, with materials, thickness, and processes determined from finite element analysis modeling. Tuf-Edge® leading edge erosion and UV protection is a standard with this blade.

The individually balanced blades can be replaced independently - matched sets are not required

RECOMMENDED TOOLS

- Long T-Handle Allen Wrench Set (3/16" to 3/8")
 - Medium Size Flat Head Screw Driver
 - Brass Ball Peen Hammer
 - Flat Bastard File
 - 240 Grit Sand Paper
 - Anti-Seize Lubricant
 - WD-40
 - 12" Crescent Wrench
- Shop Towels
 - Exact-A-Pitch® Digital Protractor (P/N 62375)
 - 25 ft. Measuring Tape
 - Pencil or Marker
 - Open/Box End Wrench Set (1/2" - 1-1/2")
 - Socket Set for 1/2" Drive (1/2" - 1-1/2")
 - Torque Wrench(s) Rated for 0-200 ft-lb.

INSTALLATION PROCEDURES

ASSEMBLY WITH BUSHING

Clean all mating surfaces between hub, bushing and shaft. All grease and lubricant should be removed, leaving the mating surfaces dry.

If there is no shoulder on shaft to prevent bushing from sliding down shaft, slide spacer/sleeve (not provided) on shaft before bushing or use a thrust retainer (optional equipment) on top of hub. Slide bushing and key onto shaft until flush with end of shaft. The shaft size determines the bushing type (U1). Lock bushing on shaft by tightening the set screw in flange with an Allen Wrench. Line up key and set hub on bushing. Engage the three (3) cap screws in flange of bushing into hub spool, using a torque wrench with a socket, and tighten evenly. Use the following table to determine the proper tools and torque values.

Bushing Size	Allen Wrench Size	Cap Screw Size	Socket Size	Torque (ft-lb) Dry
U1	3/16"	5/8"	15/16"	140

ASSEMBLY WITH STRAIGHT SHAFT (NO BUSHING)

Clean all mating surfaces between the hub and the shaft. If there is no shoulder on shaft to prevent hub from sliding down shaft, slide spacer/sleeve (not provided) on shaft before hub or use a thrust retainer (optional equipment) on top of hub. Install key in shaft. Line up key and keyway and set hub on shaft. Tighten set screw(s) in hub.

ASSEMBLY WITH TAPERED SHAFT (NO BUSHING REQUIRED)

Clean all mating surfaces between the hub and shaft.

Align keyways and install hub. Install retainer plate and cap screw(s) with lock washer(s). Shaft size determines what size cap screw is necessary. Using a torque wrench with a socket, evenly tighten cap screw to recommended standard per table below.

Cap Screw Size	Socket Size	Torque Value (ft-lb)	
		Lubricated	Dry
5/8" NC	15/16"	100	110
3/4" NC	1-1/8"	125	130
1" NC	1-1/2"	150	160

NOTE: Retaining arrangement varies with gear shaft design.

THRUST RETAINER (optional equipment)

Install proper load bolt (not provided) into top of fan shaft and tighten (See Figure 1). Install thrust retainer channel on top hub plate using existing hub spool cap screws. Torque cap screws to 60-65 ft-lb. Install thrust retainer eyebolt and jam nut. Hand tighten eyebolt. Tighten jam nut securely against top of thrust retainer channel.

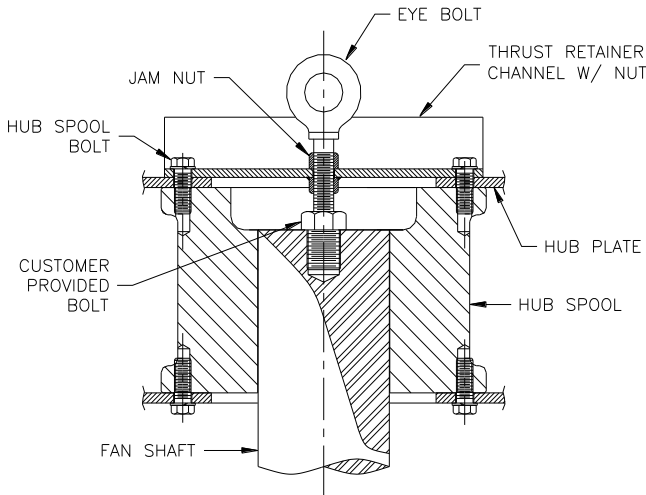

Figure 1

BLADE INSTALLATION

Remove blade clamp bolts, nuts, lock washers, and blade clamp halves from hub. Assemble blade clamp halves over groove in blade neck, and install into hub (See Figure 2). The thick leading edge will be to your left and thin trailing edge will be to your right as you stand at end of blade.



Figure 2

Install clamp bolts through hub plates and blade clamp, putting bolt heads on top, lock washers and nuts on bottom. Tighten lightly (See Figure 3).



Figure 3

SET PITCH AND TRACK

Use Hudson EXACT-A-PITCH[®] digital protractor (See Figure 4) or a bubble protractor to set blade pitch. Mount protractor on a flat bar as a base and place it approximately 1" from tip of blade. Note pitch on protractor. Rotate fan 360°, noting high and low pitch readings. Locate place where pitch reading is at mid-point between high and low readings, and set pitch at that point.



Figure 4

Rotate blade in clamp until digital protractor shows specified pitch angle to within $\pm 0.2^\circ$. Fan pitch angle is shown on fan specification sheet for design duty. After desired pitch angle is set, raise and lower end of fan blade and find mid-point of blade travel. Hold blade at the midpoint. Pull blade outward so that the blade neck flange rests against the back of the blade clamps. Push blade to the right to remove all slack.

Use torque wrench to tighten clamp bolts to 120 ft-lb (lubricated) or 130 ft-lb (dry). Re-check pitch setting. Blade must be set within $\pm 0.2^\circ$ of desired pitch angle. Tighten clamp bolts evenly. **DO NOT OVER-TORQUE CLAMP BOLTS.**

When bolts are tightened, hold a pencil against top end of blade and mark the level onto a fixed object, such as a pole or the fan ring.

Install remaining blades at same place as first blade, following the instructions above. After tightening bolts, mark top end of each blade in same place first blade was marked. If marks differ by 1" or more, adjust blade.

CHECK TRACK

After fan is installed in fan stack cylinder ring, outline top side of each blade onto fan stack cylinder ring with a marker (See Figure 5). The difference between levels of highest and lowest outlines should not be more than 1". Correct blade track by loosening clamp bolts and adjusting blade to match track of other blades. Re-tighten bolts and re-check track and pitch angle setting. Re-tighten blade clamp bolts to recommended standard of 100 ft-lb (lubricated) or 125 ft-lb (dry) torque.



Figure 5

SEAL DISC ASSEMBLY & INSTALLATION

Install self adhesive rubber gaskets on both flanges of one seal disc half. Bolt two halves of seal disc together, using 3/8" NC bolts, flat washer, lock washer, and nut. Torque to 15 ft-lb (lubricated) and 20 ft-lb (dry).

Install 3/8" NC bolts at six (6) places on top hub plate (See Figure 6). Threaded portion of bolts must be pointing up to mount seal disc. Install lock washer, nut, and flat washer on each bolt. Tighten 3/8" NC nuts to 15 ft-lb (lubricated) and 20 ft-lb (dry).

Locate the six (6) mounting holes in seal disc and install over the six (6) bolts pointing up on upper hub plate. If difficulty is encountered, loosen bolts on seal flanges until seal disc can be mounted, then re-tighten to 15 ft-lb (lubricated) or 20 ft-lb (dry).

NOTE: The purpose of the seal disc is to prevent hot air from recirculating back down through the hub, increasing efficiency.

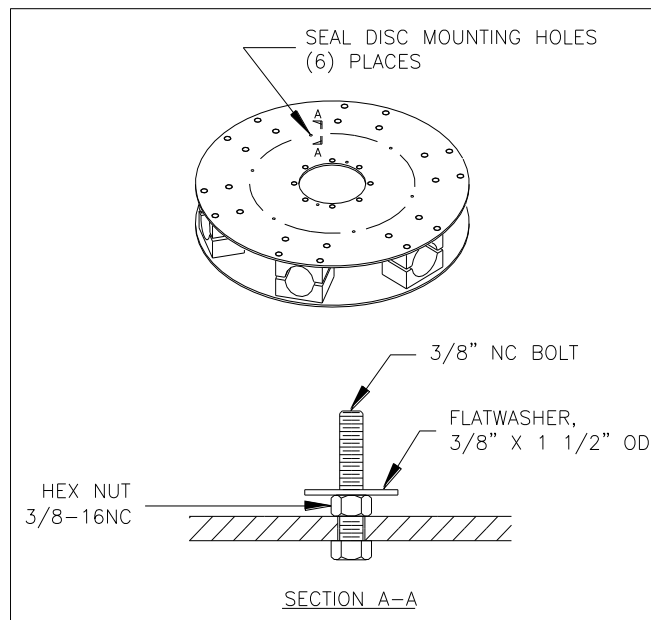

Figure 6

After mounting, install flat washer, lock washer, and 3/8" NC nuts. Tighten to 15 ft-lb (lubricated) or 20 ft-lb (dry). (See Figure 7)

Note: Refer to instructions included with seal disc for further details.

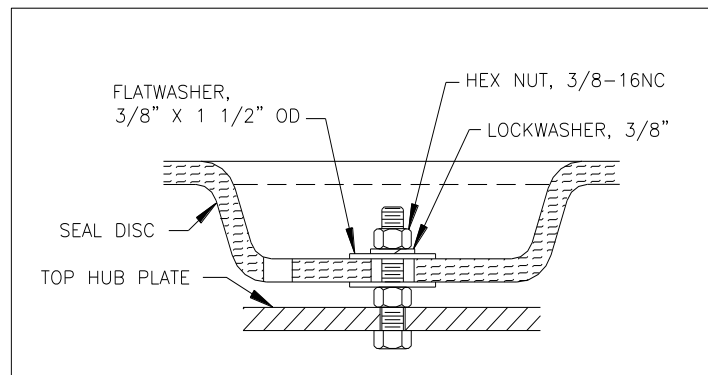

Figure 7

CHECKING TIP CLEARANCE

Rotate fan in position inside fan stack to check tip clearance (See Figure 8). The recommended tip clearance is between 1" and 1 1/2". Check for spots where fan blade clearance is not within the recommended tolerance. If necessary, adjust fan stack by shimming to obtain proper clearance.

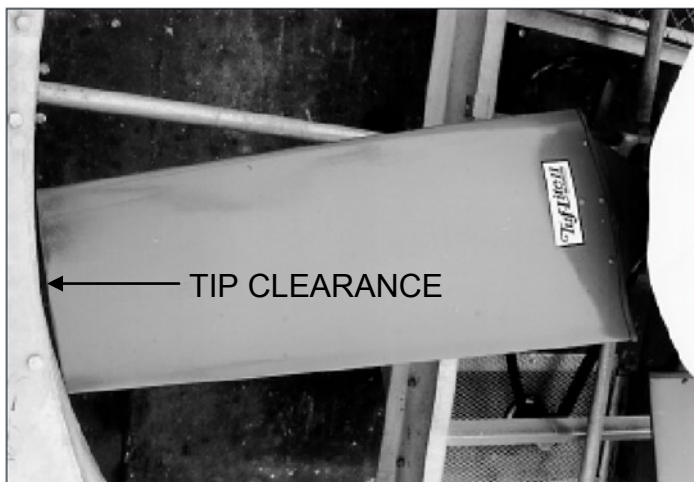

Figure 8

OPERATING INSTRUCTIONS

Start fan and check rotation. Viewed from top (discharge), fan blades should rotate clockwise.

Hudson recommends to re-verify the blade clamp torque after the initial 10-15 minutes of cold operation (i.e., the fan doesn't need to be exposed to the working temperature of the process). This will ensure that the blades are settled within the clamps after the centrifugal forces have acted.

Check motor power consumption to be sure fan is pulling desired load. **CAUTION:** If positive pitch is set in summer to use all available motor amps (nameplate rating), motor could be overloaded in winter. Design pitch angles usually do not use all of the available motor horsepower. This ensures that the motors will not be overloaded at low winter temperatures.

For the fans that have remained idle (such as a shut-down or turn-around), it is highly recommended to re-verify the torque on the blade clamps before putting it back into operation.

PART LIST
HUDSON PRODUCTS CORPORATION
 Adjustable Pitch Fan Assembly 32' 8" Diameter
 Series 6000MK HUB

ITEM	DESCRIPTION	TYPE	PART NO	NO. OF BLADES															
				6	7	8	9	10	11	12	13	14	15	16	17	18	19	20	
	32.8 Ft. Diameter Fan Shaft: 4.25" to 5.50" Dia.	U-1	Hub Assy No. Part No.	6806M D6066M	6807M D6067M	6808M D6068M	6809M D6069M	6810M D6070M	6811M D6071M	6812M D6072M	6813M D6073M	6814M D6074M	6815M D6075M	6816M D6076M	6817M D6077M	6818M D6078M	6819M D6159M	6820M D6160M	
1	81.75" Dia Hub Plate (2 Per Hub)	U-1	Part No	D6046M	D6047M	D6048M	D6049M	D6050M	D6051M	D6052M	D6053M	D6054M	D6055M	D6056M	D6057M	D6058M	D6059M	D6060M	
ITEM	DESCRIPTION		PART NO	QUANTITY PER ASSEMBLY															
2	Hub Spool	U-1	65058	1	1	1	1	1	1	1	1	1	1	1	1	1	1	1	1
3	Bushing	U-1	Specify Bore	1	1	1	1	1	1	1	1	1	1	1	1	1	1	1	1
4	Blade Clamp Half, Powder Epoxy Coated Die Cast Alum (Standard) Option 1: Powder Epoxy Coated Ductile Iron** Option 2: Coal Tar Epoxy Coated Ductile Iron**		D5131 65013 65013C	12	14	16	18	20	22	24	26	28	30	32	34	36	38	40	
5	Blade Clamp Bolt W/ Nut 3/4"-10 x 10" (Mech. Galv.)		79299	24	28	32	36	40	44	48	52	56	60	64	68	72	76	80	
6	3/4" Flat washer (316 SS)		73720	54	62	70	78	86	94	102	110	118	126	134	142	150	158	166	
7	3/4" Lock washer (Mech. Galv.)		73738	27	31	35	39	43	47	51	55	59	63	67	71	75	79	83	
8	Hub Spool Cap Screw 5/8"-11 x 1 1/2" (316 SS)		72402	16	16	16	16	16	16	16	16	16	16	16	16	16	16	16	
9	5/8" Flat washer (316 SS)		73719	48	48	48	48	48	48	48	48	48	48	48	48	48	48	48	
10	5/8" Lock washer (316 SS)		73731	16	16	16	16	16	16	16	16	16	16	16	16	16	16	16	
11	Stiffener Ring		D6004	1	1	1	1	1	1	1	1	1	1	1	1	1	1	1	
12	Stiffener Ring Bolt w/ Nut 5/8"-11 x 1 3/4" (Mech. Galv.)		15347	16	16	16	16	16	16	16	16	16	16	16	16	16	16	16	
13	5/8" Lock washer (Mech. Galv.)		73730	16	16	16	16	16	16	16	16	16	16	16	16	16	16	16	
14	Eye Bolt W/ Nut 3/4"-10 x 2" (Mech. Galv.)		59547	3	3	3	3	3	3	3	3	3	3	3	3	3	3	3	
15	Pin, Grooved, 1/2" X 1-1/2"		74540	4	4	4	4	4	4	4	4	4	4	4	4	4	4	4	
16	110" Diameter "K" Seal Disc Kit*		D6102	1	1	1	1	1	1	1	1	1	1	1	1	1	1	1	
17	Tuf-Lite III® Blade (Teal Green)		(Varies)	6	7	8	9	10	11	12	13	14	15	16	17	18	19	20	

* Includes all hardware (316 SS) to assembly and mount.

** Recommended on concrete and round towers, or corrosive environments. Contact Hudson for pricing.

HUDSON PRODUCTS CORPORATION
Adjustable Pitch Fan Assembly 32.8' Diameter
Series 6000MK HUB

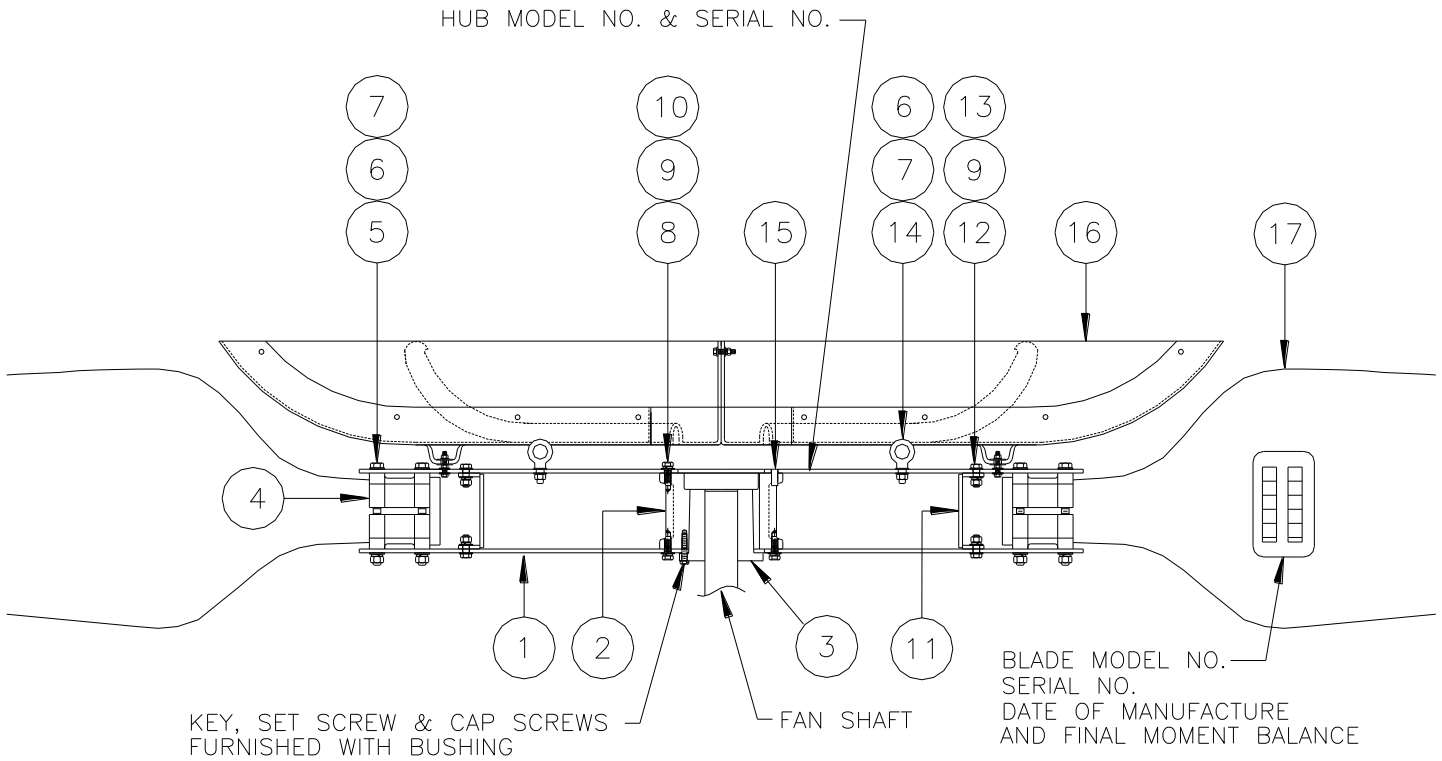

STANDARD MATERIALS & FINISHES

Blades: Fiberglass reinforced vinyl ester or epoxy

Hub Spool: Ductile Iron, Zinc Rich Coating

Plates: Coal Tar Epoxy coated steel

Bushing: Malleable Iron

Seal Disc: Fiberglass Reinforced Polyester

Blade Clamps:

Powder Epoxy Coated Die Cast Alum (Standard)

Powder Epoxy Coated Ductile Iron (Option 1)

Coal Tar Epoxy Coated Ductile Iron (Option 2)

Fasteners:

Steel, Mech. Galvanized & 316 SS Opt.

Complete Fan with 316 SS (Option 1)

Complete Fan with K500 Monel (Option 2)

WHEN ORDERING, SPECIFY FAN DIAMETER, TYPE & NUMBER OF BLADES & SHAFT DIAMETER

EXAMPLE:

APT

Fan Model
Adjustable Pitch

32.8K

Fan Diameter & Blade Type
(Specify "K" for Tuf-Lite III® Blades)
(Uses 30K Blades)

8

Number
of Blades

4 1/2" BORE

Shaft Diameter

HUDSON

Products Corporation

9660 Grunwald Rd.

Beasley, Texas 77417-8600

Phone: 281-396-8100

Fax: 281-396-8388

1-800-634-9160 (24 Hours)

[EMAIL: HUDSONPRODUCTS@HUDSONPRODUCTS.COM](mailto:HUDSONPRODUCTS@HUDSONPRODUCTS.COM)

<http://WWW.HUDSONPRODUCTS.COM>

Hudson, Auto-Variable, Combin-Aire, Exact-A-Pitch, Fin-Fan, Heatflo, Hy-Fin, Split-Flo, Solo Aire, Stac-Flo, Steamflo, Thermflo, Tuf-Edge, Tuf-Lite, Tuf-Lite II, and Tuf-Lite III are registered trademarks of Hudson Products Corporation.

©2012 Hudson Products Corp. All Rights Reserved.