

INSTALLATION MANUAL

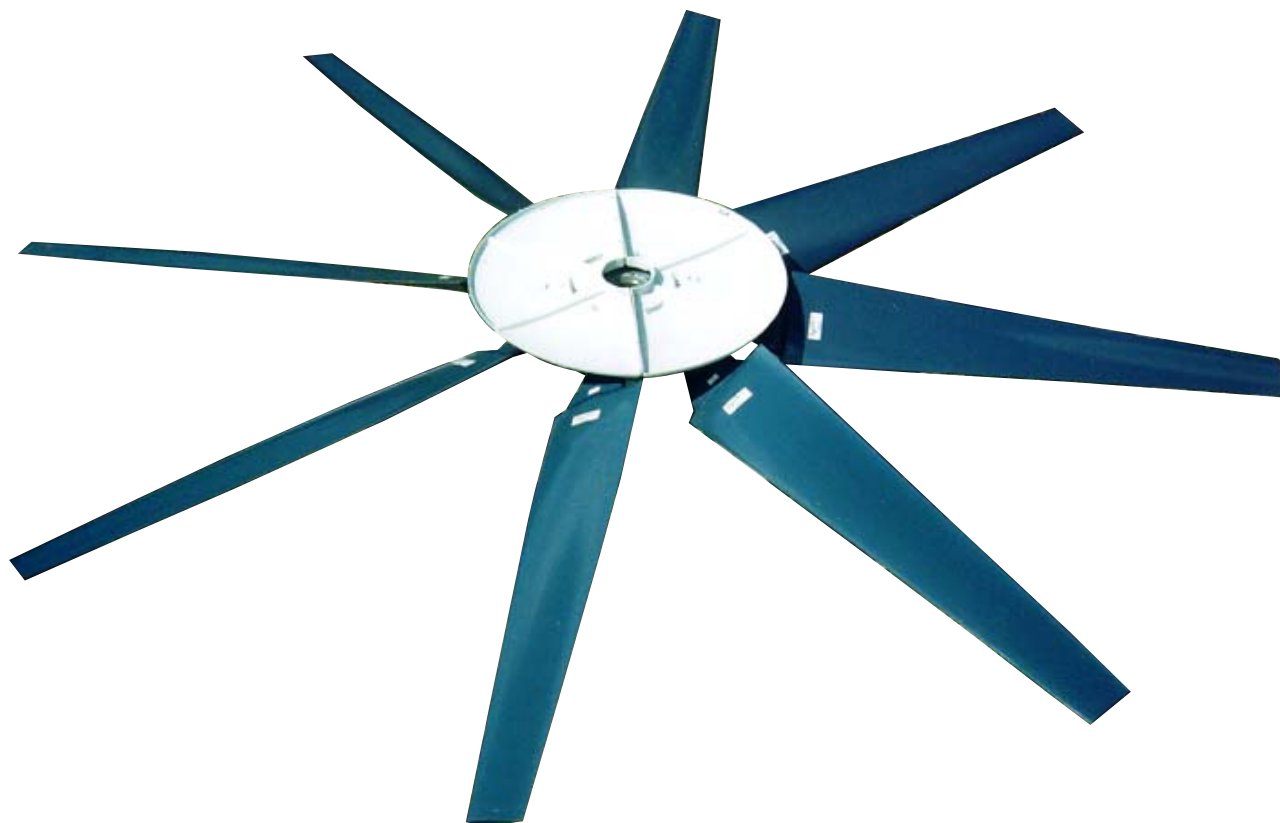

Adjustable Pitch Fan Assembly 34' through 40' Diameter

Hudson Tuf-Lite[®] and Tuf-Lite II[®] fan blades

Hudson Tuf-Lite[®] (black) fan blades are made from fiberglass reinforced epoxy resin having a very high strength-to-weight ratio and corrosion resistance (not shown).

Hudson Tuf-Lite II[®] (white, prev. blue**) fan blades are made from fiberglass reinforced vinyl-ester resin having a very high strength-to-weight ratio and superior ultra-violet and corrosion resistance. An elastomeric blade/holder joint cover (not shown) prevents moisture from entering the blade (shown above).

The individually balanced blades can be replaced independently – matched sets are not required.

RECOMMENDED TOOLS

- Long T-Handle Allen Wrench Set (3/16" to 3/8")
- Medium Size Flat Head Screw Driver
- Brass Ball Peen Hammer
- Flat Bastard File
- 240 Grit Sand Paper
- Anti-Seize Lubricant
- WD-40
- 12" Crescent Wrench

- Shop Towels
- Exact-A-Pitch® Digital Protractor (P/N 62375)
- 25 ft. Measuring Tape
- Pencil or Marker
- Open/Box End Wrench Set (1/2" - 1-1/2")
- Socket Set for 1/2" Drive (1/2" - 1-1/2")
- Torque Wrench(s) Rated for 0-250 ft-lb.

INSTALLATION PROCEDURES

ASSEMBLY WITH BUSHING

Clean all mating surfaces between hub, bushing and shaft. If there is no shoulder on shaft to prevent bushing from sliding down shaft, slide spacer/sleeve (not provided) on shaft before bushing. Slide bushing and key onto shaft until flush with end of shaft. Lock W-2 bushing on shaft by tightening set screw in flange with 1/4" Allen Wrench. (Note: setscrew is not present on all bushings) Line up key and set hub on bushing. Engage the four (4) 3/4" cap screws in flange of bushing into hub spool. Using a torque wrench with a 1-1/8" socket, tighten evenly to recommended standard of 250 ft-lb (dry).

ASSEMBLY WITH STRAIGHT SHAFT (NO BUSHING)

Clean all mating surfaces between the hub and the shaft. If there is no shoulder on shaft to prevent hub from sliding down shaft, slide spacer/sleeve (not provided) on shaft before hub or use a thrust retainer (optional equipment) on top of hub. Install key in shaft. Line up key and keyway and set hub on shaft. Tighten two (2) set screws in hub.

ASSEMBLY WITH TAPERED SHAFT (NO BUSHING REQUIRED)

Clean all mating surfaces between hub and shaft. Coat all mating surfaces with an anti-seize or lubricating compound.

Align keyways and install hub. Install retainer plate and cap screw(s) with lock washer(s). Shaft size determines what size cap screw is necessary. Using a torque wrench with a socket, evenly tighten cap screw to recommended standard per table below.

Cap Screw Size	Socket Size	Torque Value (ft-lb)	
		Lubricated	Dry
5/8" NC	15/16"	100	110
3/4" NC	1-1/8"	125	130
1" NC	1-1/2"	150	160

NOTE: Retaining arrangement varies with gear shaft design.

ASSEMBLE BLADE CLAMP ON BLADE NECK

Remove blade clamp studs, lock washers, and blade clamp halves from hub. Assemble blade clamp halves over groove in blade neck, with thick leading edge to left and thin trailing edge to right as you stand at end of blade. Use a band clamp to hold the two blade clamp halves in position on the blade for installation in the hub body (See Figure 1).



Figure 1

INSTALL BLADE INTO HUB

Hoist the blade into position. (Blade and clamp halves weight about 300 lbs.) Slide blade clamp into blade arm plates and install four (4) blade studs, eight (8) lockwashers and eight (8) nuts (See Figure 2). Tighten lightly.



Figure 2

SET PITCH AND TRACK

Use Hudson EXACT-A-PITCH® digital protractor (Shown in Figure 3) or a bubble protractor to set blade pitch. Mount protractor on a flat bar as a base and place it approximately 1" from tip of blade. Note pitch on protractor. Rotate fan 360°, noting high and low pitch readings. Locate place where pitch reading is a mid-point between high and low readings, and set pitch at that point.

Rotate blade in clamp until digital protractor shows specified pitch angle to within $\pm 0.2^\circ$. (Fan pitch angle is shown on fan specification sheet for design duty.)

After desired pitch angle is set, raise and lower end of fan blade and find midpoint of blade travel. Hold blade at the midpoint. Pull blade back so that it sits against blade clamp. Push blade to the right to remove all slack.

Use torque wrench to tighten clamp bolts to recommended standard of 280 ft-lb (lubricated) or 300 ft-lb (dry). Recheck pitch setting. Blade must be set within $\pm 0.2^\circ$ of desired pitch angle. Tighten clamp bolts evenly. **DO NOT OVER-TORQUE CLAMP BOLTS.**



Figure 3

When bolts are tightened, hold a pencil against top end of blade and mark the level onto a fixed object, such as a pole or the fan ring.

Install remaining blades at same place as first blade, following procedures above. After tightening bolts, mark top end of each blade in same place first blade was marked. If marks differ by 1-1/2" or more, adjust blade.

CHECK TRACK

After fan is installed in fan ring, outline top end of each blade onto fan ring with a marker. The difference between levels of highest and lowest outlines should not be more than 1-1/2". Correct blade track by loosening clamp bolts and adjusting blade to match track of other blades. Retighten bolts and recheck track and pitch angle setting. Retighten blade clamp bolts to recommended standard of 280 ft-lb (lubricated) or 300 ft-lb (dry) torque (See Figure 4).



Figure 4

ASSEMBLE SEAL DISC AND MOUNTING BOLTS

Place seal-disc quarter section on hub, aligning the pear-shaped opening over one of the eye-bolts (See Figure 6) and drop the seal-disc quarter section onto the nearest group of seal-disc bracket stud pairs. Remove adhesive backing on nitrile gasket section and apply gasket to seal-disc flange surface carefully such that holes in gasket lineup with the holes in the flange (See Figure 7). Repeat these operations with the next three seal-disc quarter sections, ensuring that seal-disc balance match-marks are aligned.



Figure 5



Figure 6



Figure 7

Make final adjustments to the quarter sections such they mate properly with each other and all seal-disc bracket studs, install the fasteners loosely joining each seal-disc section using one flat washer against the fiberglass surface on each side, one 3/8" hex bolt, lock washer, and hex nut at each flange hole location (See Figure 8). Ensure final fit-up of the seal-disc sections, check flatness and alignment of pear-shape openings with the eye-bolts, and snug all fasteners. Complete fasteners (Figure 9) at each bracket location (two per bracket) using a seal disc mounting pad (P/N A8105), a flat washer, lock washer, and hex nut according to Detail A on page 6, Parts List. Snug these fasteners.

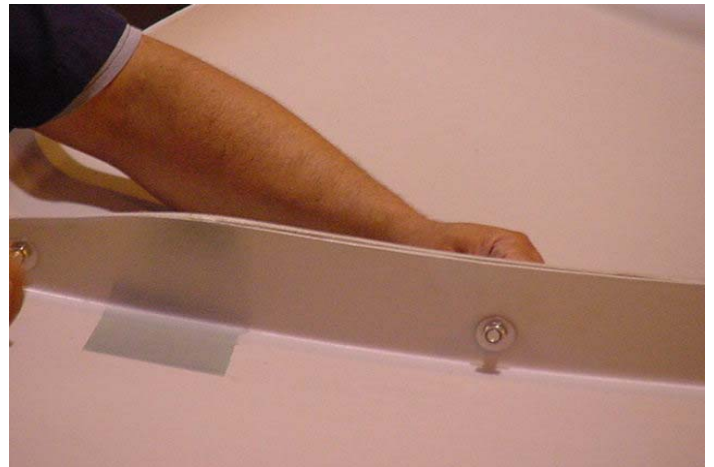

Figure 8

Using a measuring tape in several radial locations, double-check the seal-disc assembly such that it is centrally located on the hub. Make any final adjustments as necessary to ensure concentricity and trueness then tighten all fasteners at the flange surfaces and bracket studs to 15 ft-lbs lubricated or 20 ft-lbs non-lubricated. Make sure that all other details of fan installation is complete and be sure to remove all tools, loose parts, and materials from the completed hub assembly prior to startup.



Figure 9



Figure 10

NOTE: The purpose of the seal disc is to prevent hot air from recirculating back down through the hub, increasing efficiency.

CHECK TIP CLEARANCE

Rotate fan in position inside fan ring or fan stack to check tip clearance. Check for spots where fan blade clearance is less than 3/4" or greater than 1-1/2" from fan ring (See Figure 11). If necessary adjust fan ring or fan stack by shimming to obtain proper clearance. Note that different cooling towers may have different ways to adjust the fan ring or fan stack.



Figure 11

OPERATING INSTRUCTIONS

Start fan and check rotation. Viewed from top, fan blades should rotate clockwise.

Check motor power consumption to be sure fan is pulling desired load. **CAUTION:** If positive pitch is set in summer to use all available motor amps (nameplate rating), motor could be overloaded in winter. Design pitch angles usually do not use all of the available motor horsepower. This ensures that the motors will not be overloaded at low winter temperatures.

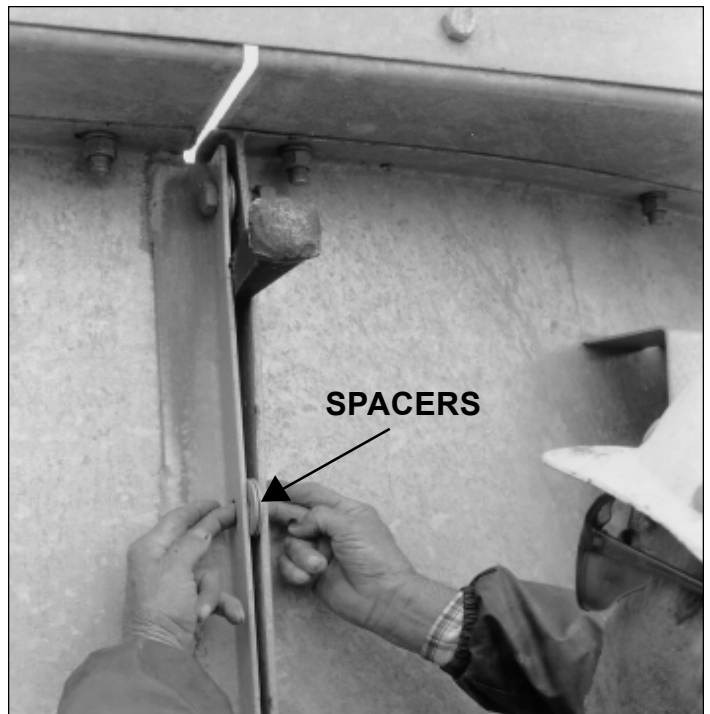

Figure 12

PARTS LIST

8000 Series Hub - Adjustable Pitch Fan Assembly (34' through 40' Diameter)

PARTS LIST				NO OF BLADES									
ITEM	DESCRIPTION	TYPE	PART. NO	6	7	8	9	10	11	12	13	14	
	Up to 7.44 Diameter Shaft	W-2	Hub Assy. No. Part. No.	8906 D8116	8907 D8117	8908 D8118	8909 D8119	8910 D8120	8911 D8121	8912 D8122	8913 D8123	8914 D8124	
1	Hub Plate (2 Per Hub)	W-2	Part. No	D8126	D8135	D8128	D8129	D8130	D8131	D8132	D8133	D8134	
ITEM	DESCRIPTION	TYPE	PART. NO	QUANTITY PER ASSEMBLY									
2	Hub Spool	W-1	65060	1	1	1	1	1	1	1	1	1	
3	Bushing	W-1	Specify Bore	1	1	1	1	1	1	1	1	1	
4	Blade Clamp Half, Coal Tar Epoxy Coated Gray Cast Iron (Standard) Option 1: Powder Epoxy Coated Gray Cast Iron Option 2: Customer Specified Coating of Gray Cast Iron		65018 65018S (Varies)	12	14	16	18	20	22	24	26	28	
5	Blade Clamp Stud W/ 2 Nuts 1"-8 x 14-1/2" (Mech. Galv.)		70643	24	28	32	36	40	44	48	52	56	
6	1" Flat washer (Mech. Galv.)		57402	48	56	64	72	80	88	96	104	112	
7	1" Lock washer (Mech. Galv.)		73742	48	56	64	72	80	88	96	104	112	
8	Hub Spool Cap Screw 3/4"-10 x 2-1/2" (316 SS)		57027	16	16	16	16	16	16	16	16	16	
9	3/4" Flat washer (316 SS)		73720	16	16	16	16	16	16	16	16	16	
10	3/4" Lock washer (316 SS)		73739	16	16	16	16	16	16	16	16	16	
11	Blade Arm, Bottom, 44" Long		61650	6	7	8	9	10	11	12	13	14	
12	Blade Arm Stiffener, 30-5/16" Long		61660	12	14	16	18	20	22	24	26	28	
13	Blade Arm Assy, Top		D8127	6	7	8	9	10	11	12	13	14	
14	Bolt, HH, 1"-8 x 3" (Mech. Galv.)		59815	48	56	64	72	80	88	96	104	112	
15	Bolt, HH, 1"-8 x 2-1/2" (Mech. Galv.)		69927	24	28	32	36	40	44	48	52	56	
16	Nut, Heavy Hex, 1"-8NC (Mech. Galv.)		72120	72	84	96	108	120	132	144	156	168	
17	1" Flat washer (Mech. Galv.)		57402	144	168	192	216	240	264	288	312	336	
18	1" Lock washer (Mech. Galv.)		73742	72	84	96	108	120	132	144	156	168	
19	Seal Disc Bracket Weldment		B8136	8	8	8	8	8	8	8	8	8	
20	A563 GR A HDG Hex Nut portion only, bolt is integral to seal disc bracket dwg 8136, P/N B8136		15314	16	16	16	16	16	16	16	16	16	
21	Seal Disc Mounting Pad 1.50" OD X 0.375" ID X 0.25" THK		A8105	16	16	16	16	16	16	16	16	16	
22	Flat washer, 3/8" x 1-1/2" OD x 0.078 Thk (Mech Galv.)		73723	16	16	16	16	16	16	16	16	16	
23	Lock washer 3/8" (Mech. Galv.)		72974	16	16	16	16	16	16	16	16	16	
24	Cap Screw, HH, 3/8"-16NC x 3/4" (316 SS)		70033	16	16	16	16	16	16	16	16	16	
25	3/8" Lock Washer (316 SS)		73722	16	16	16	16	16	16	16	16	16	
26	Eye Bolt W/ Nut 3/4"-10 x 2" (Mech. Galv.)		59547	4	4	4	4	4	4	4	4	4	
27	3/4" Flat Washer (Mech. Galv.)		16716	8	8	8	8	8	8	8	8	8	
28	3/4" Lock Washer (Mech. Galv.)		73738	4	4	4	4	4	4	4	4	4	
29	Pin, Grooved, 1/2" X 1-1/2"		74540	4	4	4	4	4	4	4	4	4	
30	160" Diameter Seal Disc Kit *		D8053	1	1	1	1	1	1	1	1	1	
31	Seal Disc Joint Gasket		73047	4	4	4	4	4	4	4	4	4	
32	Seal Disc Cap Screw, HH, 3/8"-16NC x 2" (316 SS)		53622	24	24	24	24	24	24	24	24	24	
33	Seal Disc Hex Nut, 3/8" (316 SS)		72050	24	24	24	24	24	24	24	24	24	
34	Seal Disc Flat Washer 3/8" x 1" OD (316 SS)		73623	48	48	48	48	48	48	48	48	48	
35	Seal Disc Lock Washer 3/8" (316 SS)		73722	24	24	24	24	24	24	24	24	24	
36	Tuf-Lite II® Fan Blade (White) **		(Varies)	6	7	8	9	10	11	12	13	14	
	Tuf-Lite® Fan Blade (Black)		(Varies)	6	7	8	9	10	11	12	13	14	

* Includes all hardware items 20 thru 23 and 31 thru 35 to assembly and mount.

** Blade color was blue prior to March 2006.

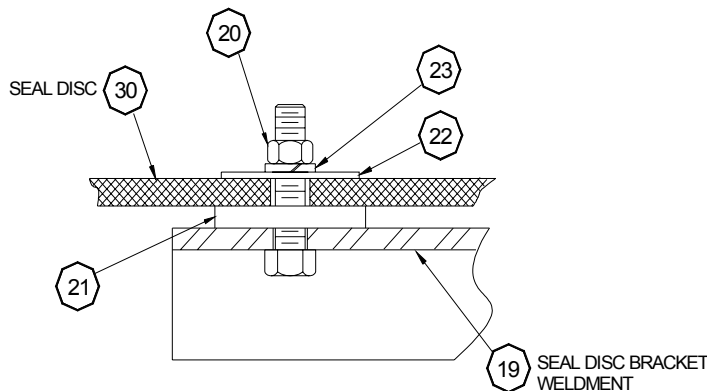

DETAIL A
SEAL DISC MOUNTING (16) PLACES TYP.
(2) PLACES ON EACH BRACKET

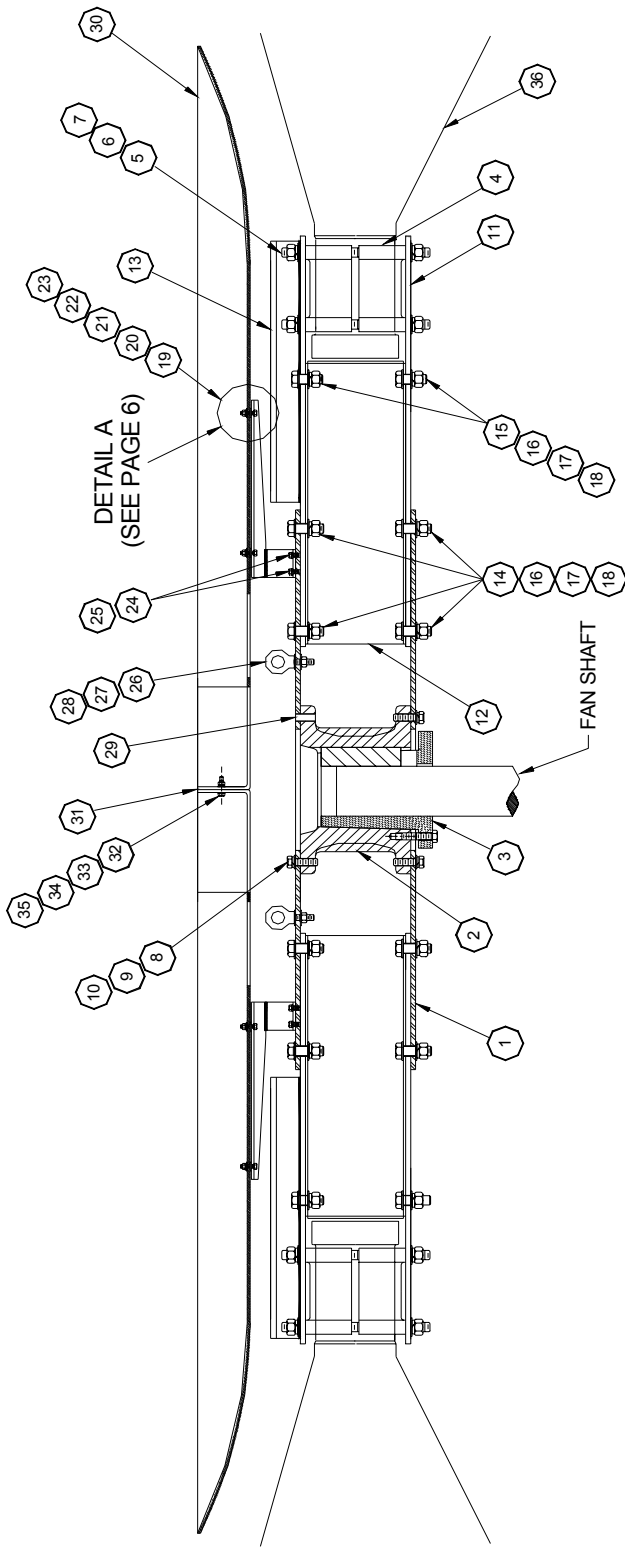

STD. MATERIALS & FINISHES:

- Blades:** Fiberglass Reinforced Vinyl Ester
- Hub Spool:** Ductile Iron, Zinc Rich Coating
- Plates:** Coal Tar Epoxy coated steel
- Bushing:** Malleable Iron
- Seal Disc:** Fiberglass Reinforced Polyester

- Blade Clamps:**
 - Coal Tar Epoxy Coated Gray Cast Iron (Standard)
 - Powder Epoxy Coated Gray Cast Iron (Option 1)
 - Customer Specified Coating of Gray Cast Iron (Option 2)
- Fasteners:**
 - Steel, Mech. Galvanized & 316 SS Opt.
 - Complete Fan W/316 SS (Option 1)
 - Complete Fan W/K500 Monel (Option 2)

When Ordering, Specify Fan Diameter, Type and Number of Blades and Shaft Diameter

EXAMPLE:	APT	40B	10	6 1/2" BORE
	Fan Model	Fan Diameter and Blade Type (Specify "H" for Tuf-Lite II® Blades) (Specify "B" for Tuf-Lite® Blades)	Number of Blades	Shaft Diameter
	Adjustable Pitch			

HUDSON PRODUCTS CORPORATION
Adjustable Pitch Fan Assembly 34' Thru 40' Diameter
Series 8000 HUB

HUDSON

Products Corporation

1307 Soldiers Field Drive
Sugar Land, Texas 77479-4072
Post Office Box 20029
Sugar Land, Texas 77496-0029
Phone: (281) 275-8100
Fax: (281) 275-8388
1-800-634-9160 (24 Hours)
EMAIL: HUDSON.products@HUDSONproducts.com
<http://www.hudsonproducts.com>

Hudson, Auto-Variable, Combin-Aire, Exact-A-Pitch, Fin-Fan, Heatflo, Hy-Fin, Split-Flo, Solo Aire, Stac-Flo, Steamflo, Thermflo, Tuf-Edge, Tuf-Lite, and Tuf-Lite II are registered trademarks of Hudson Products Corporation.