

# ACCU-PAC<sup>®</sup> COMPONENTS

• Drift Eliminator Supports • Dri-Seals • ACCU-Grid

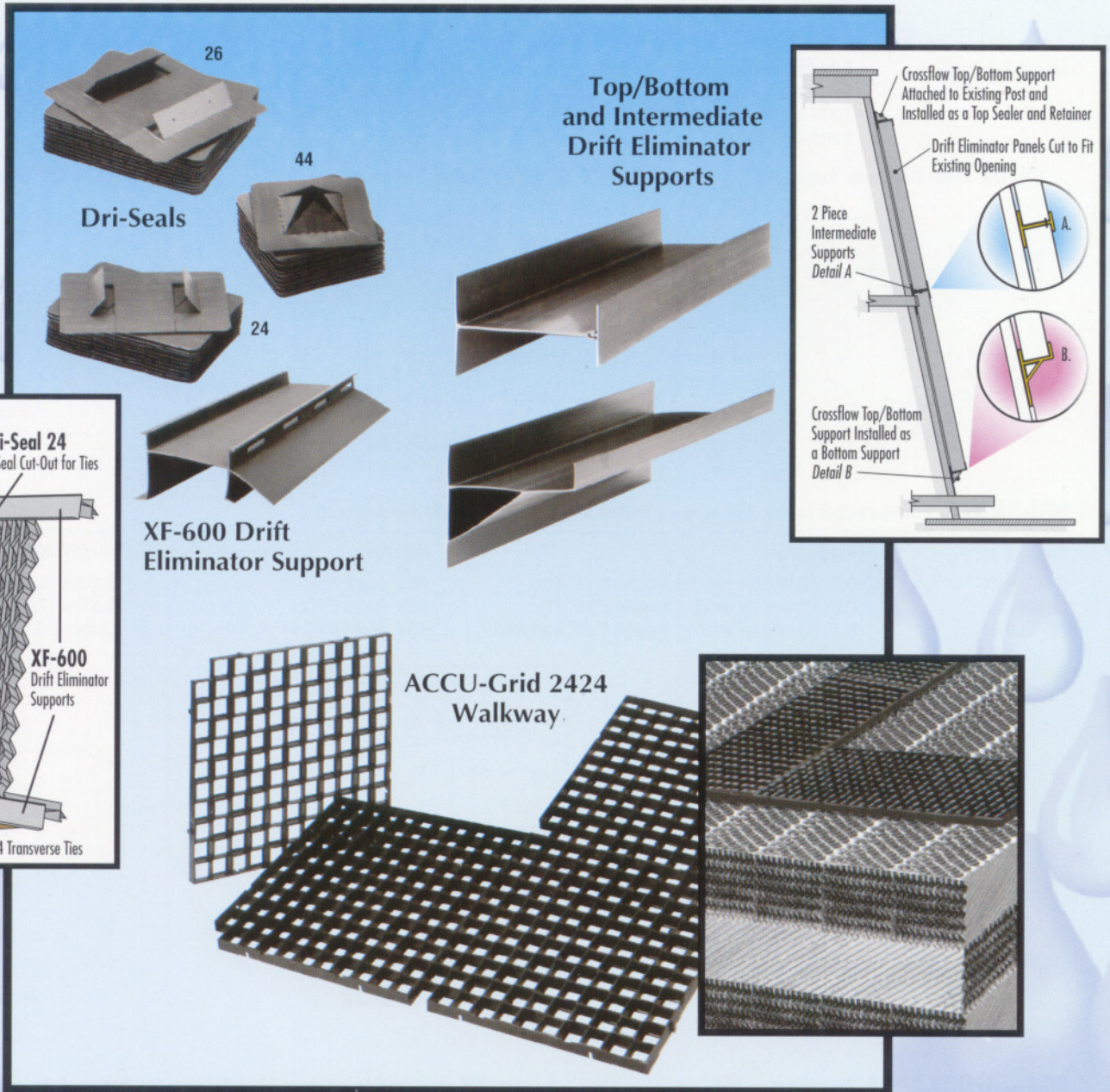

Brentwood Industries provides high quality tower components for industrial and commercial applications. The above products are designed to provide easy installation (saving man-hours), are manufactured of non-corrosive, heavy gage plastic (for long life) and provide a neat/engineered finish to your project.

 **BRENTWOOD**  
INDUSTRIES

# Accu-Pac® Components

## DRIFT ELIMINATOR SUPPORTS Provide low cost, high quality, quick installation

Product	Application	Material	Span	Std. Length	Weight/ ft (m)
CF/DE Top/Bottom Support	Top and Bottom support for Drift Eliminators in Crossflow towers, to be mounted on existing inclined posts	Rigid PVC w/UV protection	4' (1220mm)	8' (2440mm) & 12' (3660mm)	1.1lbs. (1.7 kg)
CF/DE Intermediate Support and Retainer	Drift Eliminator intermediate support with DE retainer to be mounted on existing inclined posts in Crossflow Towers.	Rigid PVC w/UV protection	4' (1220mm)	8' (2440mm) & 12' (3660mm)	.75lbs. (1.1 kg)
XF 600 DE Support	Top and Bottom support for Drift Eliminators in Crossflow Towers. To be mounted on existing transverse ties.	Rigid PVC w/UV protection	6' (1830mm) * 4' (1220mm)	8' (2440mm) & 12' (3660mm)	1.5lbs. (2.3 kg)

\*with supplementary support

**CF/DE Top/Bottom Support**

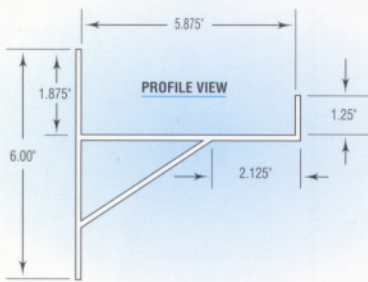

**CF/DE Intermediate Support**

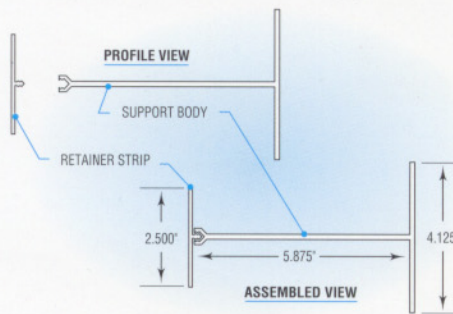

**XF-600 DE Support**

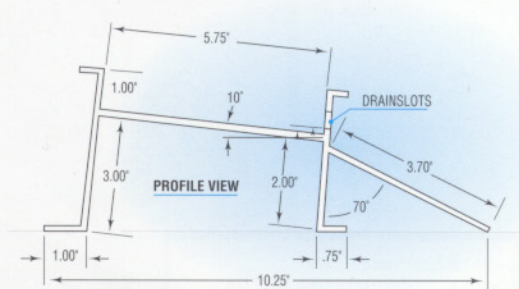

## DRI-SEALS Eliminate air leaks and reduce installation time for Drift Eliminators

Product	Application	Material	Weight/100pcs.	Color
Dri-Seal 24	Drift Eliminator sealing around 2"x4" Ties	.034" Rigid PVC	12.1 lbs. (5.5 kg)	Black
Dri-Seal 26	Drift Eliminator sealing around 2"x6" Ties	.034" Rigid PVC	15.5 lbs. (7.1 kg)	Black
Dri-Seal 44	Drift Eliminator sealing around 4"x4" support	.034" Rigid PVC	7.3 lbs. (3.3 kg)	Black

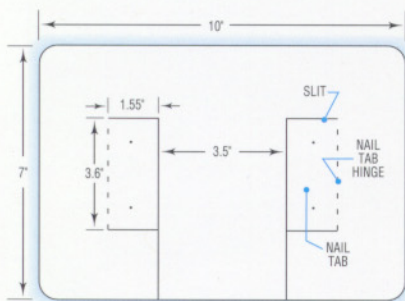

**Dri-Seal 24**

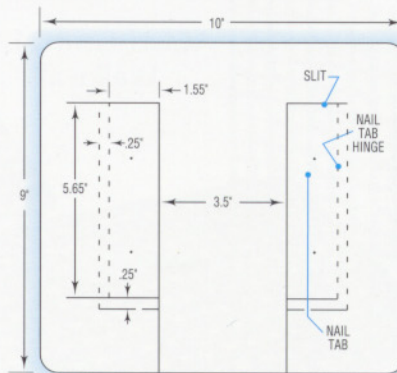

**Dri-Seal 26**

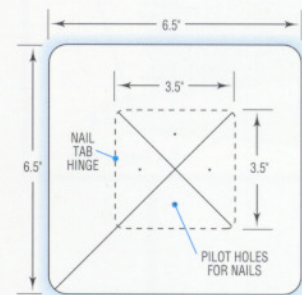

**Dri-Seal 44**

## ACCU-GRID 2424 Designed to provide an access way over fill area and to protect the fill from workmen damage and nozzle blowout

Product	Application	Material	Dimension	Weight	Color	Lock System
Accu-Grid 2424	Installed over fill media. Includes interlocking edge to ensure a solid work base, orientation notched to aid in positioning and small spiked surface for traction.	Copolymer Polypropylene	1.25" x 24" x 24" (32 mm) (610 mm) (610 mm) 2" x 2" (50 mm x 50 mm) openings	2.1 lbs. (.95 kg) per panel	Black	

\*Request "Brentwood's Installation Drawing" for further detail.

LOCKS 2 POINTS ON ALL 4 SIDES

**BRENTWOOD**  
INDUSTRIES

© Brentwood Industries 1999

Brentwood Industries, Inc.  
610 Morgantown Rd., Reading, PA 19611  
P.O. Box 605, Reading, PA 19603, U.S.A.  
610-236-1100 FAX: 610-236-1199  
email: ctsales@brentw.com